

## Decaying states as complex energy eigenvectors in generalized quantum mechanics

E. C. G. Sudarshan, C. B. Chiu, and Vittorio Gorini\*

*Center for Particle Theory, Department of Physics, The University of Texas, Austin, Texas 78712*

(Received 15 April 1977)

We reexamine the problem of particle decay within the Hamiltonian formalism. By deforming contours of integration, the survival amplitude is expressed as a sum of purely exponential contributions arising from the simple poles of the resolvent on the second sheet plus a background integral along a complex contour  $\Gamma$  running below the location of the poles. We observe that the time dependence of the survival amplitude in the small-time region is strongly correlated to the asymptotic behavior of the energy spectrum of the system; we compute the small-time behavior of the survival amplitude for a wide variety of asymptotic behaviors. In the special case of the Lee model, using a formal procedure of analytic continuation, we show that a complete set of complex energy eigenvectors of the Hamiltonian can be associated with the poles of the resolvent and the background contour  $\Gamma$ . These poles and points along  $\Gamma$  correspond to the discrete and the continuum states, respectively. In this context, each unstable particle is associated with a well-defined object, which is a discrete generalized eigenstate of the Hamiltonian having a complex eigenvalue, with its real and negative imaginary parts being the mass and half-width of the particle, respectively. Finally, we briefly discuss the analytic continuation of the scattering amplitude within this generalized scheme, and note the appearance of "redundant poles" which do not correspond to discrete solutions of the modified eigenvalue problem.

### I. STATES WITH COMPLEX ENERGY?

The dynamical equations of quantum theory allow one to calculate the state of a system at any time, given the initial state of the system. In particular, every state of a system whose Hamiltonian  $H$  has a purely continuous spectrum undergoes a substantial change in the course of time. On the other hand, if there exist discrete eigenstates of the Hamiltonian, these would simply change their phase in the course of time.

In many cases of interest there are "approximate eigenstates" of the Hamiltonian, which are suitable normalizable superpositions of the continuum eigenvectors. These change in such a fashion that their overlap with the initial state has an exponential dependence on time to a very good approximation over a large range of time values. Such states are natural models for "decaying states" representing unstable particles or, more generally, unstable systems. Since the Hamiltonian is taken to be a self-adjoint operator, there can be no eigenstate which has a strict complex exponential dependence on time. The notion of a "decaying state" which has a discrete complex energy is therefore an approximation within the scheme of conventional quantum mechanics.

The question naturally arises whether it is possible to extend the framework of quantum theory so that an unstable particle can be defined in a precise manner. If this is possible, we may be able to see in what sense an unstable state, or more generally states with complex energies, may be associated with the physical system and its Hamiltonian.

After all, we do compute lifetimes within the framework of the usual quantum theory.

We already have some clues as to the direction in which a generalization can be carried out. Using the standard representation of the unitary evolution  $U(t) = e^{-iHt}$  as the inverse Laplace transform of the resolvent,  $R = (H - zI)^{-1}$ , the survival amplitude of the unstable state as a function of time can be expressed as a contour integral encircling the energy spectrum, the discontinuity of the integrand being associated with the spectral energy density of the unstable state. Under quite general conditions, this expression can be estimated for various time domains by deforming the integration contour, making use of the assumed analytic properties of the integrand. For a domain of time values, the amplitude is dominated by the contribution coming from (one or more) poles in the integrand of the contour integral. These poles are therefore closely associated with the notion of the unstable states. We may expect that such an analytic continuation, if it can be defined for the state space itself, should give us the required generalization. We shall see that this is indeed the case.

In the usual framework, on quite general grounds, it can be shown that a strictly exponential decay is not possible. Both at very short and at very long times, the decay should depart from the exponential. However, model calculations indicate that detection of such deviations, if possible at all, requires measurements to be carried out under extremely stringent conditions.<sup>1</sup> Although to our knowledge this nonexponential behavior has not yet been verified experimentally, since its deduction

is based on such simple and general considerations, it may be accepted as valid.<sup>1-6</sup> On the other hand, Prigogine and his collaborators<sup>7</sup> have criticized this conclusion and argued that an absolute dependence on the "time lived" by the unstable state is tantamount to not defining an unstable particle as an autonomous entity. Working in the context of the density-matrix formalism of quantum statistical mechanics, they have urged the consideration of new objects<sup>7</sup> which could have purely exponential dependence on time, despite the fact that such objects would be outside the framework of standard quantum mechanics. In this paper, we give an explicit construction of such generalized states within the framework of an extended Hamiltonian formalism. The rigorous mathematical treatment of this theory will appear in a separate paper.<sup>8</sup>

Even apart from the question of unstable states, the general theory of analytic continuation of scattering amplitudes and its relation to the theory of generalized states is of intrinsic interest. Stated quite simply: Given a scattering amplitude computed within the framework of a standard quantum theory as the boundary value of an analytic function, and given an analytic continuation of the amplitude which rearranges the branch cuts of the amplitude from the real to a complex contour, does there exist a generalized theory from which the analytically continued amplitude can be computed directly along with its complex branch cuts? This question is answered affirmatively in this paper.

The purpose of this paper is twofold:

1. It deals with the necessary generalization of quantum theory to associate complex energy eigenstates to a Hamiltonian which is self-adjoint in a Hilbert space. Under quite general conditions, the scheme can be related to the Lee model (Friedrichs-Lee model).<sup>9,10</sup> The generalized spectra and the corresponding complete sets of generalized states of the model associated with arbitrary contours are worked out. It is shown that under suitable conditions one or more discrete unstable states are necessary for completing the set of generalized eigenstates of the Hamiltonian associated with a given complex contour. The time dependence of these states is obtained by standard analytic continuation arguments.

2. We use the time dependence so computed to make better estimates for the small-time behavior of the survival amplitude. It is further shown that in the evaluation of the time dependence of the survival amplitude only unstable states contribute, whereas there are contributions to the scattering amplitude from a set of "redundant poles", which are not associated with states. These poles originate from the poles of the form factors. The no-

tions of phase equivalence and redundant poles of the  $S$  matrix, known previously for real energy poles,<sup>11,12</sup> are here extended to complex poles.

On the basis of classical probability theory, we would expect that an autonomous unstable particle would exhibit a purely exponential behavior. Repeated observation, or any other method of destroying phase information, would lead to such a behavior. This point of view has been investigated extensively by various authors.<sup>13</sup>

A related approach to the treatment of resonances and unstable states is based on the method of dilatation analytic perturbations for  $N$ -particle systems<sup>14-17</sup> which, in the special case of the Lee model, has been studied by Weder.<sup>18</sup> The difference between this method and ours is the following. In the treatment based on dilatation analyticity, one considers a family of Hamiltonians  $H(\nu) = U(\nu)HU(\nu)^{-1}$ , where  $H$  is the Hamiltonian of the system and  $U(\nu)$ ,  $\nu$  real, is a unitary representation of the group of dilatations. Under suitable conditions on the potential,  $H(\nu)$  can be analytically continued to a strip  $\{\nu \mid |\operatorname{Im}\nu| < \alpha\}$ , for some  $\alpha > 0$ , and  $H^\dagger(\nu) = H(\nu^*)$ . If  $\operatorname{Im}\nu > 0$ ,  $H(\nu)$  is a non-self-adjoint operator whose continuous spectrum is along complex contours in the lower half-plane originating at the (real and complex) thresholds, and resonant states appear as Hilbert space eigenvectors of  $H(\nu)$  corresponding to discrete eigenvalues which are second-sheet poles of the analytic continuation of a certain family of matrix elements of the resolvent. In other words, in this approach, resonant states are associated to *proper eigenvectors* of an analytically continued *non-self-adjoint Hamiltonian*. On the other hand, in our treatment, these states are described by *discrete generalized eigenvectors* of the *original Hamiltonian* (compare also Ref. 8). The corresponding complex eigenvalues  $E_0 - i\Gamma_0/2$  ( $E_0$  the resonant energy,  $\Gamma_0$  the resonance width) are of course the same, and in both cases one obtains the correct decomposition of the survival amplitude as a sum of exponential contributions plus a background integral [compare Eq. (4.17) and Ref. 17, p. 157]. Our method bears a closer connection to the approach of Baumgartel,<sup>19</sup> who also associates resonance to generalized eigenvectors of the Hamiltonian.

Finally, we would like to remark that in the context of Lee-Friedrichs<sup>9,10</sup> or Wigner-Weisskopf<sup>20</sup> model Hamiltonians, an *exact* exponential decay at all times for the survival amplitude can be obtained only in the so-called weak-coupling (or Van Hove) limit, corresponding to vanishing coupling constant  $g \rightarrow 0$  and rescaled time  $\tau = g^2 t$  (Ref. 21) (or by essentially equivalent limiting procedures leading to a singular Hamiltonian<sup>22,23</sup>). This result

is a particular case of a more general theory of quantum Markovian master equations.<sup>23</sup>

II. THE DYNAMICS OF DECAY

Let  $H$  denote the Hilbert space of states of a quantum-mechanical system with self-adjoint Hamiltonian  $H$ . For simplicity, we assume its spectrum to be Lebesgue and nondegenerate. The temporal evolution of the states of the system is described by the family of unitary operators

$$U(t) = e^{-iHt} = \frac{1}{2\pi i} \int dz e^{-izt} \frac{1}{H - zI}, \tag{2.1}$$

where the integration is along a contour to be specified below. If  $|M\rangle$  is an arbitrary normalized state, its spectral energy density is defined by

$$p(\lambda) = \frac{d}{d\lambda} (M | F_\lambda | M) = (M | \lambda)(\lambda | M) = |(\lambda | M)|^2, \tag{2.2}$$

where  $F_\lambda$  is the spectral family of projections of the Hamiltonian

$$H = \int \lambda dF_\lambda = \int \lambda | \lambda \rangle \langle \lambda | d\lambda. \tag{2.3}$$

The function  $p(\lambda)$  is non-negative, integrable to unity, and vanishes outside the spectrum of  $H$ .<sup>24</sup> Since the latter is purely continuous,  $|M\rangle$  is non-stationary, and its survival amplitude is given by

$$\begin{aligned} a(t) &= (M | e^{-iHt} | M) = \int e^{-i\lambda t} d(M | F_\lambda | M) \\ &= \int e^{-i\lambda t} \rho(\lambda) d\lambda, \end{aligned} \tag{2.4}$$

where the integration extends over the spectrum of  $H$  which may be taken to be  $0 < \lambda < \infty$  without loss of generality. (Note that if one so chooses, without much effort one can also allow for the presence of a finite number of point eigenvalues corresponding to discrete eigenstates of the Hamiltonian.) The survival probability is

$$Q(t) = |a(t)|^2 = \left| \int_0^\infty e^{-i\lambda t} \rho(\lambda) d\lambda \right|^2. \tag{2.5}$$

As long as  $H$  is semibounded, it is easy to show that  $Q(t)$  cannot have a strict exponential dependence. For a systematic study of this question, see for instance Refs. 1, 2, and 4.

Making use of the resolvent  $R(z) = (H - zI)^{-1}$ , we define

$$\beta(z) = -\langle M | R(z) | M \rangle = - \int_0^\infty \frac{\rho(\lambda) d\lambda}{\lambda - z}. \tag{2.6}$$

Then the survival amplitude is given by

$$a(t) = \frac{i}{2\pi} \int_C e^{-izt} \beta(z) dz, \tag{2.7}$$

where the contour  $C$  is shown in Fig. 1. The func-

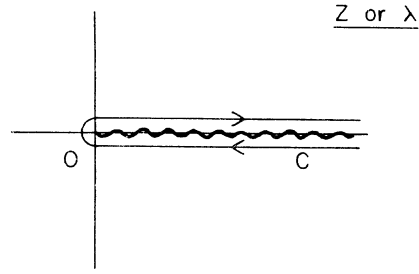

FIG. 1. The contour  $C$ .

tion  $\beta(z)$  is analytic in the plane cut along the positive real axis, it is free of zeros there, and its discontinuity across the cut is given by

$$\lim_{\epsilon \rightarrow 0_+} [\beta(\lambda + i\epsilon) - \beta(\lambda - i\epsilon)] = -2\pi i \rho(\lambda). \tag{2.8}$$

Hereafter we will drop the limit symbol with the understanding that “ $\pm i\epsilon$ ” will always designate the two appropriate sides of a cut and  $\epsilon \rightarrow 0_+$ . The inverse function

$$\gamma(z) = \frac{1}{\beta(z)}, \tag{2.9}$$

is analytic and free of zeros in the cut plane by virtue of the non-negativity of  $\rho(\lambda)$ .

So far,  $\rho(\lambda)$  can be any normalized non-negative function, as no restriction has been placed on the state  $|M\rangle$ . But in order for  $|M\rangle$  to represent a resonant state, one usually requires the analytic continuation of the function  $\gamma(z)$  through the cut into the lower right quadrant to have a zero near the real axis. If we assume  $\gamma(z)$  to have the asymptotic behavior

$$|\gamma(z) - z + m| \xrightarrow{|z| \rightarrow \infty} \text{const} \times z^\delta, \tag{2.10}$$

with  $\delta \leq 0$ , then it has the integral representation

$$\gamma(z) = z - m + \frac{1}{\pi} \int_0^\infty \frac{|f(\lambda)|^2 d\lambda}{\lambda - z}, \tag{2.11}$$

with

$$|f(\lambda)|^2 = \frac{1}{2i} [\gamma(\lambda + i\epsilon) - \gamma(\lambda - i\epsilon)]. \tag{2.12}$$

On the other hand, if  $0 < \delta < 1$ , then  $\gamma(z)$  satisfies a once-subtracted dispersion relation,

$$\begin{aligned} \gamma(z) &= z - E_s + y(E_s) \\ &+ \frac{(z - E_s)}{\pi} \int_0^\infty \frac{|f(\lambda)|^2 d\lambda}{(\lambda - z)(\lambda - E_s)}. \end{aligned} \tag{2.13}$$

Notice that as long as  $\delta < 1$ , from (2.7) and (2.9) by deforming the contour  $C$ , one can easily check that  $a(0) = 1$ .

This same survival amplitude is obtained in the Lee model with a discrete state  $|M\rangle$  and a continuum of states  $|E\rangle$ ,  $0 < E < \infty$ , with a "free Hamiltonian"  $H_0$  and an "interaction Hamiltonian"  $H_I$ , which couples this discrete state to the continuum by a perturbation of strength  $f(E)$ . The nondecay amplitude for the state  $|M\rangle$  is expressed by the contour integral (2.7), with the function

$$f(E) \propto \langle E | H_I | M \rangle. \quad (2.14)$$

Therefore we may consider this model as a *general* example of resonant amplitudes.

The model may be stated precisely as follows. The Hilbert space of the system is defined as the set of vectors of the form  $\Phi = \begin{pmatrix} \zeta \\ \phi(E) \end{pmatrix}$ , where  $\zeta$  is a complex number and  $\phi(E)$  is a complex-valued (measurable) function defined in  $0 < E < \infty$ , such that

$$\int_0^\infty |\phi(E)|^2 \sigma(E) dE < \infty, \quad (2.15)$$

where  $\sigma(E)$  is a positive (measurable) phase-space factor to be defined below. The inner product is given by

$$\langle \Phi | \Phi' \rangle = \zeta^* \zeta' + \int_0^\infty \phi^*(E) \phi'(E) \sigma(E) dE. \quad (2.16)$$

The Hamiltonian  $H$  is defined by

$$H = H_0 + H_I = \begin{pmatrix} m & g^*(E') \sigma(E') \\ g(E) & E \delta(E - E') \end{pmatrix}. \quad (2.17)$$

So

$$H_0 \begin{pmatrix} \zeta \\ \phi(E') \end{pmatrix} = \begin{pmatrix} m \zeta \\ E \phi(E) \end{pmatrix}, \quad (2.17a)$$

$$H_I \begin{pmatrix} \zeta \\ \phi(E') \end{pmatrix} = \begin{pmatrix} \int_0^\infty g^*(E') \phi(E') \sigma(E') dE' \\ g(E) \zeta \end{pmatrix}. \quad (2.17b)$$

It is convenient to define the function

$$\alpha(z) = z - m + \int_0^\infty \frac{|g(E)|^2 \sigma(E) dE}{E - z}. \quad (2.18)$$

Here  $\alpha(z)$  corresponds to the quantity  $\gamma(z)$  in (2.9) with the asymptotic behavior of (2.10) assumed here. If the integral (2.18) does not converge, one may express  $\alpha(z)$  in terms of the once-subtracted dispersion relation as given in (2.13), so as to admit the asymptotic behavior with  $0 < \delta < 1$ .

If  $\alpha(z) = 0$  has a real solution at  $z = \lambda_0$  [which is negative, provided  $f(E)$  does not vanish for  $0 < E < \infty$ ], a discrete eigenvector exists for the eigenvalue equation

$$H \begin{pmatrix} \delta \\ \phi \end{pmatrix} = \lambda \begin{pmatrix} \zeta \\ \phi \end{pmatrix}. \quad (2.19)$$

Otherwise there are no normalizable eigenvectors.

The normalized solution, when it exists, is of the form

$$\psi_0 = \begin{pmatrix} \zeta_0 \\ \phi_0(E) \end{pmatrix}, \quad (2.20)$$

where

$$\zeta_0 = \frac{1}{(\alpha'_0)^{1/2}}, \quad \text{with } \alpha'_0 = \left. \frac{d\alpha}{d\lambda} \right|_{\lambda=\lambda_0} \quad (2.20a)$$

and

$$\phi_0(E) = \frac{g(E)}{\lambda_0 - E} \zeta_0. \quad (2.20b)$$

The continuum solutions have the form

$$\psi_\lambda = \begin{pmatrix} \zeta_\lambda \\ \phi_\lambda(E) \end{pmatrix}, \quad (2.21)$$

with

$$\zeta_\lambda = \frac{g^*(\lambda) \sigma^{1/2}(\lambda)}{a(\lambda + i\epsilon)} \quad (2.21a)$$

and

$$\begin{aligned} \phi_\lambda(E) &= \sigma^{-1/2}(\lambda) \delta(\lambda - E) \\ &+ \frac{\sigma^{1/2}(\lambda) g^*(\lambda) g(E)}{(\lambda - E + i\epsilon) a(\lambda + i\epsilon)}, \quad \lambda \in (0, \infty). \end{aligned} \quad (2.21b)$$

They satisfy the orthonormality relations

$$|\zeta_0|^2 + \int_0^\infty |\phi_0(E)|^2 \sigma(E) dE = 1, \quad (2.22a)$$

$$\zeta_0^* \zeta_\lambda + \int_0^\infty \phi_0^*(E) \phi_\lambda(E) \sigma(E) dE = 0, \quad (2.22b)$$

$$\zeta_\lambda^* \zeta_0 + \int_0^\infty \phi_\lambda^*(E) \phi_0(E) \sigma(E) dE = 0, \quad (2.22c)$$

$$\zeta_\lambda^* \zeta_{\lambda'} + \int_0^\infty \phi_\lambda^*(E) \phi_{\lambda'}(E) \sigma(E) dE = \delta(\lambda - \lambda'), \quad (2.22d)$$

which may be rewritten as

$$\langle \psi_0 | \psi_0 \rangle = 1, \quad (2.22a)$$

$$\langle \psi_0 | \psi_\lambda \rangle = 0, \quad (2.22b)$$

$$\langle \psi_\lambda | \psi_0 \rangle = 0, \quad (2.22c)$$

$$\langle \psi_\lambda | \psi_{\lambda'} \rangle = \delta(\lambda - \lambda'). \quad (2.22d)$$

Moreover, these solutions are complete in the sense that

$$|\psi_0\rangle \langle \psi_0| + \int_0^\infty |\psi_\lambda\rangle \langle \psi_\lambda| d\lambda = I, \quad (2.23)$$

which has the componentwise expressions

$$|\zeta_0|^2 + \int_0^\infty |\zeta_\lambda|^2 d\lambda = 1, \quad (2.23a)$$

$$\phi_0(E')\xi_0^* + \int_0^\infty \phi_\lambda(E')\xi_\lambda^* d\lambda = 0, \quad (2.23b)$$

$$\xi_0\phi_0^*(E) + \int_0^\infty \xi_\lambda\phi_\lambda^*(E)d\lambda = 0, \quad (2.23c)$$

$$\phi_0(E')\phi_0^*(E) + \int_0^\infty \phi_\lambda(E')\phi_\lambda^*(E)d\lambda = \delta(E' - E)\sigma^{-1}(E). \quad (2.23d)$$

These relations can be easily verified by contour integrations. The actual calculation is a special case of the more general treatment given in Appendix A. The essential step in the calculation is to convert the integration with respect to  $z$  (or  $\lambda$ ) from 0 to  $\infty$  into a contour integration in the complex plane making use of the relation

$$\alpha(z + i\epsilon) - \alpha(z - i\epsilon) = 2\pi i |g(z)|^2 \sigma(z). \quad (2.24)$$

For this system, in view of the completeness relation, we expect no other solutions. If the parameters of the theory are such that the equation  $\alpha(\lambda) = 0$  has no solution, then there is no discrete solution  $\psi_0$ : The continuum eigenvectors form a complete set by themselves.

### III. THE SURVIVAL AMPLITUDE

The survival probability of the “unstable particle” was defined as the squared absolute value of the survival amplitude

$$\begin{aligned} a(t) &= \frac{i}{2\pi} \int_C \frac{e^{-izt} dz}{\gamma(z)} \\ &= \int_0^\infty \frac{e^{-iEt} |g(E)|^2 \sigma(E) dE}{|\gamma(E + i\epsilon)|^2}. \end{aligned} \quad (3.1)$$

This is a general expression, but if we so wish, we can specialize it to the model considered in the preceding section. For very long times, the behavior of  $a(t)$  depends on the small-energy behavior of the phase-space factor  $\sigma(E)$ , provided the form factor  $g(E)$  behaves smoothly for small  $E$ . In this case, since  $\sigma(E) \propto E^{1/2}$  for small  $E$ , by using  $Et$  as the integration variable, one can easily show that for  $t \rightarrow \infty$ ,

$$a(t) \sim \text{const} \times t^{-3/2}. \quad (3.2)$$

The behavior for small  $t$  is model dependent: We shall discuss this in detail later on.

In most cases of interest, there is a large domain of values of  $t$  for which the behavior of  $a(t)$  is dominated by a complex exponential. This corresponds to a resonance behavior of the amplitude and implies that the analytic continuation of the integrand through the cut into the second sheet encounters a simple pole at  $z = E_0 - i\Gamma_0/2 = \lambda_0$  with  $E_0 \gg \Gamma_0 > 0$ . Under this condition, the above represen-

tation for the survival amplitude has a dominant contribution of the form  $e^{-iE_0 t} e^{-\Gamma_0 t/2}$  together with a “background integral”. The latter is important for very large times (in this domain it is responsible for the  $t^{-3/2}$  behavior) and for very small times.

We now proceed to look more closely at the resonance behavior of the survival amplitude using contour deformation and the analytic continuation of the discontinuity function. For definiteness, we consider explicitly the case where  $\gamma(z)$  satisfies a dispersion relation of the form

$$\gamma(z) = z - m + \frac{1}{\pi} \int_0^\infty \frac{F(x')}{x' - z} dx'. \quad (3.3)$$

For the Lee model,

$$F(x) = \pi |g(x)|^2 \sigma(x). \quad (3.4)$$

We assume that  $F(x)$  is analytically continuable and denote the unique continuation by  $F(z)$ .

To explicitly “expose” the zero (or zeros) of  $\gamma(z)$  as its “second sheet”, say at  $z = \lambda_0$ , we replace the line integral in (3.3) along  $\Gamma_1$  for  $x'$  from 0 to  $\infty$ , by contour integrals on the second sheet.<sup>25</sup> In particular, as shown in Fig. 2, the relevant contours are related as follows:

$$\Gamma_1 + C_\infty - \Gamma = S. \quad (3.5)$$

So for any  $z$  in the region bounded by  $\Gamma_1$  and  $\Gamma$  on the first sheet of  $\gamma(z)$ ,

$$\begin{aligned} \gamma(z) = \gamma_\Gamma(z) &\equiv z - m + \frac{1}{\pi} \int_\Gamma \frac{F(z')}{z' - z} dz' \\ &+ \frac{1}{\pi} \oint_S \frac{F(z')}{z' - z} dz'. \end{aligned} \quad (3.6)$$

To arrive at the right-hand side expression, we have assumed the asymptotic behavior of  $F(z)$  to be such that

$$\int_{C_\infty} \frac{F(z')}{z' - z} dz' = 0. \quad (3.7)$$

The function  $\gamma_\Gamma(z)$  is defined by the integrals on the

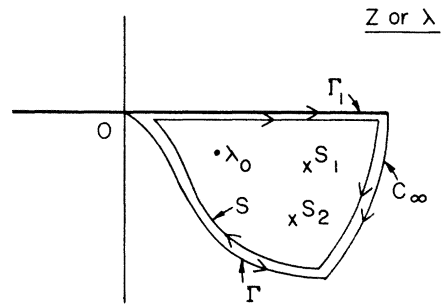

FIG. 2. The contours  $\Gamma_1$ ,  $\Gamma$ ,  $C_\infty$ , and  $s$ .  $s_1$  and  $s_2$  denote the locations of  $F(z)$  singularities.

right-hand side of (3.6).

Next replace the  $S$  integration by integrals enclosing the individual singularities  $S_1, S_2, \dots$  of  $F(z)$  (see Fig. 2). This gives

$$\gamma_{\Gamma}(z) \equiv z - m + \frac{1}{\pi} \int_{\Gamma} \frac{F(z')}{z' - z} dz' + \frac{1}{\pi} \sum_l \oint_{C_l} \frac{F(z')}{z' - z} dz', \quad (3.8)$$

where  $C_l$  designates the clockwise contour enclosing the  $l$ th singularity of  $F(z)$ . Denote the domain bounded by  $\Gamma_1$  and  $\Gamma$  on the second sheet of  $\gamma(z)$  by  $\Delta$ . Notice that  $\gamma_{\Gamma}(z)$  is well defined in this domain. So  $\gamma_{\Gamma}(z)$  now provides a unique analytic continuation of  $\gamma(z)$ , originally defined by (3.3), into this second-sheet domain.

It is instructive to demonstrate that within the domain  $\Delta$ , the second-sheet function of  $\gamma(z)$  defined by  $\gamma_{\Gamma}(z)$  and its corresponding first-sheet function have the correct discontinuity. In particular,

$$\gamma_{II}(z) - \gamma_I(z) \equiv \gamma_{\Gamma}(z) - \gamma(z) = 2iF(z).$$

To see this, we make use of the relation (3.5). It gives

$$\frac{1}{\pi} \int_{\Gamma_1} \frac{F(z')}{z' - z} dz' - \frac{1}{\pi} \int_{\Gamma} \frac{F(z')}{z' - z} dz' = \frac{1}{\pi} \oint_{S'} \frac{F(z')}{z' - z} dz'. \quad (3.9)$$

Here  $S'$  is identical to the original  $S$  contour illustrated in Fig. 2. The prime indicates that the contour now encloses the pole at  $z' = z$ , which occurs in the domain  $\Delta$ . The first sheet function  $\gamma_1$  is identical to that obtained by moving  $z$  into domain  $\Delta$  from above, with  $S$  appropriately deformed to avoid the crossing of the pole at  $z' = z$ . Thus there is the relation

$$\frac{1}{\pi} \oint_{S'} \frac{F(z')}{z' - z} dz' = -2iF(z) + \frac{1}{\pi} \oint_S \frac{F(z')}{z' - z} dz'. \quad (3.10)$$

From (3.9) and (3.10) we get the expected result:

$$\begin{aligned} \gamma_{\Gamma}(z) - \gamma(z) &= \frac{1}{\pi} \int_{\Gamma} \frac{F(z')}{z' - z} dz' + \frac{1}{\pi} \oint_S \frac{F(z')}{z' - z} dz' \\ &\quad - \frac{1}{\pi} \int_{\Gamma_1} \frac{F(z')}{z' - z} dz' = 2iF(z). \end{aligned} \quad (3.11)$$

Next consider the survival amplitude-

$$a(t) = \frac{i}{2\pi} \int_C \frac{e^{-izt}}{\gamma(z)} dz. \quad (3.12)$$

Denote

$$a_{\Gamma}(t) = \frac{i}{2\pi} \int_{C_{\Gamma}} \frac{e^{-izt}}{\gamma(z)} dz, \quad (3.13)$$

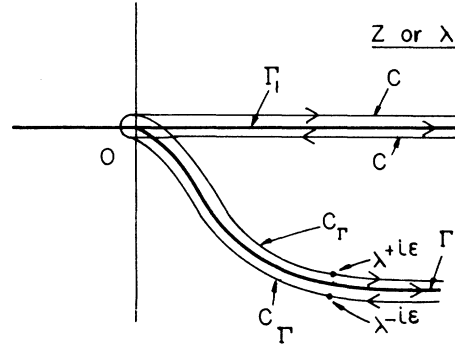

FIG. 3. The curves  $\Gamma_1$  and  $\Gamma$  and their corresponding contours  $C$  and  $C_{\Gamma}$ .

where the contour  $C_{\Gamma}$  is shown in Fig. 3. Deforming the line integral from  $\Gamma_1$  to  $\Gamma$  we arrive at the expression

$$\begin{aligned} a(t) &= a_{\Gamma}(t) + \sum \frac{e^{-i\lambda_0 t}}{\gamma'_{\Gamma}(\lambda_0)} \\ &\quad + (\text{terms due to cuts in } F). \end{aligned} \quad (3.14)$$

Technically speaking, the last term may also include the essential singularities. We will not explicitly mention them below. Notice that *poles in  $\gamma_{\Gamma}(z)$ , do not give rise to poles in the survival amplitude*. On the other hand, cuts in the analytic continuation of  $F(z)$  do give rise to extra terms on the right-hand side of (3.14). We shall also ignore these cuts in the discussion below.

Although up to this point we have only treated the case where  $\gamma(z)$  satisfies the unsubtracted dispersion relation, Eq. (3.14) is valid also for the case where  $\gamma(z)$  satisfies the once-subtracted dispersion relation. For this case, in analogy to (3.7), one assumes

$$\int_{C_{\infty}} \frac{F(z')}{(z' - z)(z' - E_0)} dz' = 0. \quad (3.15)$$

In (3.14), each term in the summation may be associated with an unstable particle, which behaves as if it had the complex energy  $\lambda_0 = E_0 - i\Gamma_0/2$ , which is the complex zero of  $\gamma(z)$ . In the context of the Lee model, since  $g(z)$  is a measure of the coupling strength, as  $|F(z)| \rightarrow 0$ , the coupling tends to zero,  $E_0 \rightarrow m$ , and  $\Gamma_0 \rightarrow 0$ . In this limit, the only zero of  $\gamma(z)$  is  $z = m$  and it is easily identified with the discrete state which becomes unstable as the coupling is turned on.

On the other hand, the poles of the form factor are independent of the coupling strength and have a geometric significance. Although these poles are absent in the decay amplitude, they are present in the scattering amplitude and are generalizations of "redundant" poles known in scattering theory for some time.<sup>11,12</sup> In the latter part of this paper, we

will discuss these poles and contrast them with the relevant “dynamical” poles coming from the zeros of the denominator function  $\gamma(z)$ .

Now we turn to the small-time behavior of the survival amplitude. Here we need to specify the asymptotic behavior of  $\gamma(z)$  more explicitly. Starting with the integral representation

$$a(t) = \frac{i}{2\pi} \int_C \frac{e^{-izt}}{\gamma(z)} dz, \quad (3.16)$$

and assuming the asymptotic behavior

$$|\gamma(z) - (z - m)| \sim \text{const} \times z^\delta, \quad -1 \leq \delta < 1$$

we proceed to consider first the case  $-1 < \delta < 1$ .

For sufficiently large  $|z|$ , we assume that the function  $\gamma(z)$  has the asymptotic expansion

$$\gamma_a(z) = \gamma(z) = z - m - \eta_\delta \sum_{l=0}^{\infty} c_l \frac{z^\delta}{(z - m)^l} e^{-i\pi(\delta - l)}, \quad (3.17)$$

where  $\eta_\delta = \text{sgn}(\delta)$ . The phase factors ensure the reality of  $\gamma(z)$  along the negative  $z$  axis on the physical sheet. The factor  $-\eta_\delta$  is introduced so that the contribution of the  $l=0$  term to  $\text{Im}\gamma(z)$  along the cut is positive-definite. Also, we chose  $L$  to be sufficiently large so that for  $|z| > L$ ,

$$|z - m| \gg \left| \sum_{l=0}^{\infty} c_l \frac{z^\delta}{(z - m)^l} e^{-i\pi(\delta - l)} \right| \sim c_0 z^\delta. \quad (3.18)$$

Divide  $C$  into  $C_s$  plus  $C_L$  as shown in Fig. 4 and rewrite

$$a(t) = \frac{i}{2\pi} \int_{C_s} \left[ \frac{1}{\gamma(z)} - \frac{1}{\gamma_a(z)} \right] e^{-izt} dz + \frac{i}{2\pi} \int_C \frac{e^{-izt}}{\gamma_a(z)} dz. \quad (3.19)$$

The first term on the right-hand side can be expanded in powers of  $t$  in the form  $b_0 + ib_1 t + O(t^2)$ , with  $b_1$  real. On the other hand, the second integral can give rise to a term with a fractional power of  $t$  for small  $t$ . We now proceed to look at this in detail.

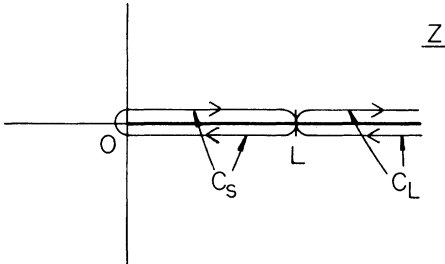

FIG. 4. The contours  $C_s$  and  $C_L$ .

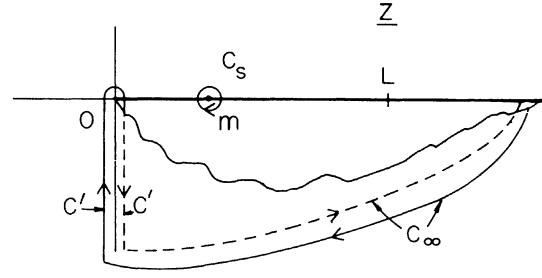

FIG. 5. Deformation of the contour  $C$  into contours  $C_s$ ,  $C'$ , and  $C_\infty$ .

Denote

$$\begin{aligned} \tilde{a}(t) &\equiv \frac{i}{2\pi} \int_C dz \frac{e^{-izt}}{\gamma_a(z)} \\ &= \frac{i}{2\pi} \int_C dz \frac{e^{-izt}}{z - m} \left[ 1 + \frac{\eta_\delta c_0 z^\delta}{z - m} e^{-i\pi\delta} + \sum_{k=1}^{\infty} \frac{g_k z^\delta}{(z - m)^{k+1}} \right]. \end{aligned} \quad (3.20)$$

Notice that the cut of  $\gamma_a(z)$  is explicitly given. It is associated with a branch point at  $z=0$ . We may deform the contour in the manner indicated in Fig. 5 and write

$$\tilde{a}(t) = \tilde{a}_s(t) + \tilde{a}'(t) + \tilde{a}_\infty(t), \quad (3.21)$$

where the right-hand side terms are contributed by the contours  $C_s$ ,  $C'$ , and  $C_\infty$ , respectively. One can easily check that  $\tilde{a}_\infty(t) = 0$ .

We state here an identity which is proved in Appendix B. For small  $t$ ,

$$\int_0^\infty du \frac{e^{-ut} u^\epsilon}{(u - ib)^\rho} = \left[ \frac{(-ib)^{1+\epsilon-\rho} \Gamma(1+\epsilon)}{\sin\pi(\epsilon - \rho) \Gamma(\rho) \Gamma(\epsilon + 2 - \rho)} - t^{\rho-1-\epsilon} \Gamma(1 - \rho + \epsilon) \right] [1 + O(t)]. \quad (3.22)$$

From (3.20)–(3.22), the term with the leading fractional power of  $t$  is given by

$$\begin{aligned} \tilde{a}'(t) &= \frac{1}{\pi} \int_0^\infty \frac{e^{-ut} \eta_\delta c_0 u^\delta}{(u - ib)^2} e^{-i(\pi/2)(\delta-1)} \sin\pi(\delta-1) \\ &\approx \frac{\eta_\delta c_0 e^{-i(\pi/2)(\delta-1)}}{\Gamma(2-\delta)} t^{1-\delta}. \end{aligned} \quad (3.23)$$

Since  $a(0) = 1$ , we have

$$a(t) = 1 + \frac{\eta_\delta c_0 e^{-i(\pi/2)(\delta-1)}}{\Gamma(2-\delta)} t^{1-\delta} + iD_1 t + \dots, \quad (3.24)$$

where  $D_1$  is real. For small  $t$ ,

$$Q(t) = |a(t)|^2 \approx 1 - \frac{2c_0 |\sin(\pi\delta/2)| t^{1-\delta}}{\Gamma(2-\delta)} \quad (3.25)$$

and

$$\dot{Q}(t) \approx -\frac{2c_0 |\sin(\pi\delta/2)|}{\Gamma(1-\delta)} t^{-\delta}. \quad (3.26)$$

This expression for the special case of  $\delta = \frac{1}{2}$  was obtained earlier in Ref. 1.

To conclude the discussion on this topic, we now look at the case where  $\delta = -1$ . Here we may write

$$\gamma(z) = z - m + \frac{1}{\pi} \int_0^\infty \frac{F(z')}{z' - z} dz'. \quad (3.27)$$

We assume that as  $z \rightarrow \infty$ ,

$$|F(z)| < \frac{1}{z^{1+\delta'}}, \quad (3.28)$$

with  $\delta' > 0$ . Then (3.27) implies that as  $|z| \rightarrow \infty$ ,

$$|\gamma(z) - (z - m)| \rightarrow \text{const} \times z^{-1}. \quad (3.29)$$

The corresponding survival amplitude is given by

$$a(t) = \frac{1}{\pi} \int_0^\infty \frac{F(z)}{\gamma(z+i\epsilon)\gamma(z-i\epsilon)} e^{-izt} dz. \quad (3.30)$$

From (3.27), as  $|z| \rightarrow \infty$ ,

$$\gamma(z+i\epsilon) \rightarrow z \quad (3.31)$$

and

$$\gamma(z-i\epsilon) = \gamma(z+i\epsilon) - 2iF(z) \rightarrow z.$$

So, for  $\delta' > 0$ , in the small- $t$  region we have

$$a(t) = 1 - iC_1 t - C_2 t^2 + R(t), \quad (3.32)$$

where  $C_1 > 0$ ,  $C_2$  is real, and as  $t$  approaches 0, the remainder  $R(t)$  approaches 0 faster than  $t^2$ .

Thus for small  $t$ ,

$$\begin{aligned} |Q(t)|^2 &= (1 - C_2 t^2)^2 + C_1^2 t^2 + \dots \\ &\approx 1 - (2C_2 - C_1^2) t^2, \\ &\quad \text{where } 2C_2 - C_1^2 > 0 \end{aligned} \quad (3.33)$$

and

$$\dot{Q}(t) \rightarrow -2(2C_2 - C_1^2)t. \quad (3.34)$$

Our consideration here is applicable to those cases, where as  $|z| \rightarrow \infty$ ,

$$F(z) < 1/z^{1+\delta'}, \quad \text{with } \delta' > 0. \quad (3.35)$$

For these cases, the second derivative of  $a(t)$  at  $t = 0$  is defined. Zeno's paradox<sup>1,5</sup> occurs when the time derivative of the survival probability vanishes at  $t = 0$ . This happens whenever  $\delta < 0$ , including the case  $\delta = -1$  considered here.

#### IV. GENERALIZED QUANTUM MECHANICS

Despite the completeness of the set of energy eigenvectors for energy eigenvalues in the spectrum

of  $H$ , we observe that a continuum of solutions of the eigenvalue equation can be associated with the *same* Hamiltonian form and any arbitrary *complex* contour  $\Gamma$  beginning at 0 and ending at infinity in the lower fourth quadrant. In order to show this, we consider the space of analytic functions  $\Sigma$  which are holomorphic in the domain  $\Delta U\Delta^*$ , where  $\Delta$  is the domain bounded by  $\Gamma$  and the positive real line  $\Gamma_1$  and such that the integral

$$\int_{\Gamma} \phi^*(z^*) \phi(z) \sigma(z) dz \quad (4.1)$$

exists. Furthermore, we require these functions to vanish fast enough as  $|z| \rightarrow \infty$  inside  $\Delta$ , so that

$$\int_{\Gamma} \phi^*(z^*) \phi(z) \sigma(z) dz = \int_0^\infty |\phi(E)|^2 \sigma(E) dE. \quad (4.2)$$

Then the space  $\Lambda$  of vectors of the form  $\psi = (\phi(z))_{\phi(z)}$ , where  $\xi$  is a complex number,  $\phi(z)$  belongs to  $\Sigma$ , and  $z$  is taken to run along  $\Gamma$ , is a pre-Hilbert space. For two vectors  $\Phi = (\phi(z))_{\phi(z)}$  and  $\chi = (\chi(z))_{\chi(z)}$  the inner product is

$$\langle \Phi | \chi \rangle = \xi^* \xi + \int_{\Gamma} \phi^*(z^*) \omega(z) \sigma(z) dz. \quad (4.3)$$

Under suitable conditions on  $\Gamma$ , the completion  $\mathcal{H}'$  of  $\Lambda$  can be identified in an obvious way with the original Hilbert space  $\mathcal{H}$  of our system by means of the isometry

$$V: \begin{pmatrix} \xi \\ \phi(z) \end{pmatrix} \rightarrow \begin{pmatrix} \xi \\ \phi(E) \end{pmatrix}. \quad (4.4)$$

In the following, we will also find it convenient to make use of the bilinear form on left vectors  $\langle \chi | = (\eta, \chi(z))$  and right vectors  $|\Phi\rangle = (\phi(z))_{\phi(z)}$  defined by

$$\langle \chi | \Phi \rangle = \eta \xi + \int_{\Gamma} \chi(z) \phi(z) \sigma(z) dz. \quad (4.5)$$

If  $\lambda$  is now taken to be a complex variable also lying on  $\Gamma$ , we can define  $\delta(\lambda - z)$  by

$$\int_{\Gamma} \phi(z) \delta(\lambda - z) dz = \phi(\lambda). \quad (4.6)$$

With this understanding, the eigenvalue problem associated with the Hamiltonian

$$(H_0 + H_I)\psi = \lambda\psi \quad (4.7)$$

can be written in the form

$$(\lambda - m)\xi = \int_{\Gamma} g^*(z^*) \phi(z) \sigma(z) dz, \quad (4.7a)$$

$$(\lambda - z)\phi(z) = g(z)\xi, \quad \lambda \in \Gamma. \quad (4.7b)$$

Then the continuum solutions have the form

$$\psi_{\lambda} = \begin{pmatrix} \xi_{\lambda} \\ \phi_{\lambda}(z) \end{pmatrix}, \quad \lambda \in \Gamma \quad (4.8)$$



with

$$\zeta_\lambda = \frac{g^*(\lambda^*)\sigma^{1/2}(\lambda)}{\alpha_\Gamma(\lambda + i\epsilon)} \quad (4.8a)$$

and

$$\phi_\lambda(z) = \sigma^{-1/2}(\lambda)\delta(\lambda - z) + \frac{\sigma^{1/2}(\lambda)g^*(\lambda^*)g(z)}{(\lambda - z + i\epsilon)\alpha_\Gamma(\lambda + i\epsilon)}. \quad (4.8b)$$

Here we have introduced the function

$$\alpha_\Gamma(z) = z - m + \frac{1}{\pi} \int_\Gamma \frac{F(\lambda)}{\lambda - z} d\lambda, \quad (4.9)$$

where  $F(z) = \pi g^*(z^*)g(z)\sigma(z)$ . If the function  $F(z)$  is analytic in the domain  $\Delta$ , (4.9) provides an analytic continuation of  $\alpha(z)$  inside the domain  $\Delta$  on the second sheet. The point  $z = \lambda + i\epsilon$  is reached by approaching  $\Gamma$  from the domain  $\Delta$ . Furthermore, if  $\lambda_0$  is any value in the complex plane cut along the contour  $\Gamma$  for which

$$\alpha_\Gamma(\lambda_0) = 0, \quad (4.10)$$

then the eigenvalue equation (4.7) has a discrete solution corresponding to the eigenvalue  $\lambda_0$  and having the form

$$\psi_0 = \begin{pmatrix} \zeta_0 \\ \phi_0(z) \end{pmatrix}, \quad (4.11)$$

with

$$\zeta_0 = 1/[\alpha'_\Gamma(\lambda_0)]^{1/2} \quad (4.11a)$$

and

$$\phi_0(z) = \frac{g(z)\zeta_0}{\lambda_0 - z}, \quad (4.11b)$$

provided  $\alpha'_\Gamma(\lambda_0)$  exists. There is a distinct discrete solution associated with each distinct simple root of the equation  $\alpha_\Gamma(\lambda) = 0$ .

Both  $\psi_0$  and  $\psi_\lambda$  are examples of "right eigenvectors"<sup>8</sup> of the total Hamiltonian. We can correspondingly obtain a set of "left eigenvectors"<sup>8</sup> which satisfy the eigenvalue equation

$$\bar{\psi}(H_0 + H_I) = \lambda \bar{\psi}. \quad (4.12)$$

The continuum solutions are of the form

$$\bar{\psi}_\lambda = (\eta_\lambda, \chi_\lambda(z)), \quad (4.13)$$

with

$$\eta_\lambda = \frac{g(\lambda)\sigma^{1/2}(\lambda)}{\alpha_\Gamma(\lambda - i\epsilon)} \quad (4.13a)$$

and

$$\chi_\lambda(z) = \sigma^{-1/2}(\lambda)\delta(\lambda - z) + \frac{\sigma^{1/2}(\lambda)g(\lambda)g^*(z^*)}{(\lambda - z - i\epsilon)\alpha_\Gamma(\lambda - i\epsilon)}. \quad (4.13b)$$

Here the point  $\lambda - i\epsilon$  is reached by approaching  $\Gamma$  from the side opposite to the domain  $\Delta$ . A discrete left eigenvector, when it exists, is of the form

$$\bar{\psi}_0 = (\eta_0, \chi_0(z)), \quad (4.14)$$

with

$$\eta_0 = 1/[\alpha'_\Gamma(\lambda_0)]^{1/2} \quad (4.14a)$$

and

$$\chi_0(z) = \frac{g^*(z^*)\eta_0}{\lambda_0 - z}, \quad (4.14b)$$

and the condition for its existence is the vanishing of  $\alpha_\Gamma(\lambda_0)$ . This is the *same* condition as that for a discrete right eigenvector.

We can now verify the orthogonality and normalization relations. They are best expressed in terms of the bilinear form specified in (4.5) in the following manner.

$$\begin{aligned} \langle \bar{\psi}_0 | \psi_0 \rangle &= 1, \\ \langle \bar{\psi}_0 | \psi_\lambda \rangle &= \langle \bar{\psi}_\lambda | \psi_0 \rangle = 0, \end{aligned} \quad (4.15)$$

and

$$\langle \bar{\psi}_\lambda | \psi_{\lambda'} \rangle = \delta(\lambda - \lambda').$$

The completeness relation takes the form

$$\sum |\Psi_0\rangle \langle \bar{\Psi}_0| + \int_\Gamma |\Psi_\lambda\rangle \langle \bar{\Psi}_\lambda| d\lambda = I, \quad (4.16)$$

where the sum stands for the collection of isolated simple roots of  $\alpha_\Gamma(\lambda) = 0$  in the cut plane. The actual calculation to establish the orthogonality and completeness relations is given in Appendix A.

We note that originally the phase-space factor  $\sigma(E)$  and the form factor  $g(E)$  were defined only for real values of  $E$ . We have chosen to consider them as boundary values of analytic functions which can be continued in the complex  $z$  plane, so as to be able to define them along the contour  $\Gamma$ .

The Hamiltonians  $H_0, H_I$  used in this framework are related to the Hamiltonians  $H_0, H_I$  used in Sec. II by a formal continuation through the isometry (4.4). The spaces of the vectors  $\Psi$  are quite distinct, but again are formally obtained by analytic continuation of the functions from the standard situation. On the basis of this and the theory constructed in this section, we are now able to calculate the analytically continued expressions for the survival amplitude explicitly and directly within the extended framework:

$$\begin{aligned}
a(t) &= \langle M | e^{-iHt} | M \rangle = \langle M | e^{-iHt} | M \rangle = \sum \langle M | \psi_0 \rangle \langle \tilde{\psi}_0 | e^{-i\lambda_0 t} | M \rangle + \int_{\Gamma} \langle M | \Psi_{\lambda} \rangle \langle \tilde{\Psi}_{\lambda} | e^{-i\lambda t} | M \rangle d\lambda \\
&= \sum \frac{1}{\alpha'_{\Gamma}(\lambda_0)} e^{-i\lambda_0 t} + \frac{1}{\pi} \int_{\Gamma} e^{-i\lambda t} \frac{F(\lambda)}{\alpha_{\Gamma}(\lambda+i\epsilon)\alpha_{\Gamma}(\lambda-i\epsilon)} d\lambda \\
&= \sum \frac{1}{\alpha'_{\Gamma}(\lambda_0)} e^{-i\lambda_0 t} + \frac{i}{2\pi} \int_{C_{\Gamma}} \frac{e^{-i\lambda t}}{\alpha_{\Gamma}(\lambda)} d\lambda, \tag{4.17}
\end{aligned}$$

where  $C_{\Gamma}$  is a clockwise contour encircling the generalized continuous spectrum along  $\Gamma$  as depicted in Fig. 6. Note that this treatment contains an implicit assumption of the type in (3.7) regarding the asymptotic behavior of  $F(z)$ , which allows us to drop the contribution of the contour at infinity. If the function  $F(z)$  has no singularities in  $\Delta$ , (4.17) coincides with the expression obtained earlier through the deformation of the contour for the survival amplitude for the standard case given in (3.14).

Within this new framework, to an unstable particle is associated a new kind of state with a complex value of the energy (compare Ref. 7). Despite this complex energy value, every such state contributes to the complete set of states and is "orthogonal" to the continuum of  $\lambda \in \Gamma$ . The wave functions of the discrete complex energy state are given by

$$\Psi_0 = \begin{pmatrix} \xi_0 \\ \frac{g(z)}{\lambda_0 - z} \xi_0 \end{pmatrix} \tag{4.18}$$

and

$$\tilde{\Psi}_0 = \left( \eta_0, \frac{g^*(z^*)}{\lambda_0 - z} \eta_0 \right), \tag{4.19}$$

and therefore depend on the contour  $\Gamma$  along which  $z$  is defined. So we see that the energy of the unstable particle is independent of the contour, but its wave function does depend on the "background" chosen. As the coupling  $g(\lambda)$  is weakened, other things being equal, the discrete wave function becomes more and more dominated by  $\xi_0$ , the contribution of the discrete state which was stable when the coupling tended to vanish. Correspondingly, the imaginary part of  $\lambda_0$  also decreases and the energy becomes "almost real".

#### V. SCATTERING AMPLITUDE: REDUNDANT POLES

We now proceed to calculate the scattering amplitude for these models. As in the usual case of the scattering problem, we compare the states of the actual system with a hypothetical "free" system in defining the scattering. We work with the "in" state of the total Hamiltonian, and find the co-

efficient of the "diverging wave" for unit "plane-wave" amplitude. For the model we have discussed, this leads to the following expression for the scattering amplitude:

$$\begin{aligned}
T(\lambda) &= - \frac{\pi |g(\lambda)|^2 \sigma(\lambda)}{\alpha(\lambda+i\epsilon)} \\
&= - \frac{F(\lambda)}{\alpha(\lambda+i\epsilon)} \\
&= e^{i\delta(\lambda)} \sin \delta(\lambda), \quad \lambda \in \Gamma_1 \tag{5.1}
\end{aligned}$$

where

$$e^{2i\delta(\lambda)} = S(\lambda) = \frac{\alpha(\lambda-i\epsilon)}{\alpha(\lambda+i\epsilon)}; \tag{5.2}$$

it is a unimodular quantity for real  $\lambda$ . As long as  $g(\lambda)$  and  $g^*(\lambda^*)$  are boundary values of analytic functions, the scattering amplitude will also be an analytic function in the cut plane with a cut along the real axis from 0 to  $\infty$ . If there is a bound state,  $\alpha(\lambda_0)=0$ ,  $\lambda_0 < 0$ , and consequently the scattering amplitude would have a pole at this location provided  $F(\lambda_0)$  does not vanish. Every such bound state corresponds to a pole of the S matrix.

This property is also true for the scattering amplitude in the generalized theory that we have constructed in Sec. V with the generalized continuous spectrum along the contour  $\Gamma$ . In this case the scattering amplitude is given by the expression

$$T(\lambda) = - \frac{F(\lambda)}{\alpha_{\Gamma}(\lambda)}, \tag{5.3}$$

with  $\alpha_{\Gamma}(\lambda)$  given in (4.9). If  $\lambda_0$  is a solution of  $\alpha_{\Gamma}(\lambda)=0$ , this implies the presence of a discrete eigenstate and also a pole in the scattering amplitude at  $\lambda=\lambda_0$ . However, in general not every pole in the scattering amplitude corresponds to a discrete state. The lack of pole-discrete-state correspondence does not show up in the generalized theory developed in Sec. IV. This is due to the fact that the theory there was restricted to the case where  $F(\lambda)$  is analytic. We shall see that poles in  $F(\lambda)$  can lead to poles in the scattering amplitude and at the same time without corresponding discrete states in the generalized completeness relation.

We now illustrate this with the simplest case where  $F(z)$  has a pole at  $\lambda = z_1$ , which occurs in the region bounded between the positive axis and the contour  $\Gamma$ , and  $\text{Im}\lambda < 0$ . Since  $F(\lambda)$  is the discontinuity function, there are two cases we need to consider. First is that, as  $\lambda \rightarrow z_1$ ,

$$\alpha_I(\lambda) \sim \text{finite} \tag{5.4}$$

and

$$\alpha_{II}(\lambda) \propto \frac{1}{\lambda - z_1},$$

and second, as  $\lambda \rightarrow z_1$ ,

$$\alpha_I(\lambda) \propto \frac{1}{\lambda - z_1} \tag{5.5}$$

and

$$\alpha_{II}(z_1) = \alpha_{II}(z_1) \sim \text{finite}.$$

For the case of (5.4), the complex variable function  $\alpha_I(\lambda)$  obeys the dispersion relation of (3.27). And it is finite everywhere on the first sheet of  $\alpha(\lambda)$  cut along the positive real axis. To ensure the Cauchy equivalence of the theory, the generalized spectrum must be along a contour which is deformable from the original contour  $C$  of Fig. 1 without exposing the pole on the second sheet of  $\alpha(\lambda)$  at  $\lambda = z_1$ . For definiteness, we continue to work with the generalized spectrum along the contour  $\Gamma$ . However, in order not to expose the pole of  $F(\lambda)$  at  $\lambda = z_1$ , for the present case it is necessary to include the additional continuum specified along some clockwise closed-contour  $C_1$  encircling the point  $\lambda = z_1$ . The generalization of (4.9) is now given by the expression [compared to (3.8)]

$$\alpha_{\Gamma}(\lambda) = \lambda - m + \frac{1}{\pi} \int_{\Gamma} \frac{F(z') dz'}{z' - \lambda} + \frac{1}{\pi} \oint_{C_1} \frac{F(z')}{z' - \lambda} dz'. \tag{5.6}$$

The continued scattering amplitude defined in the  $\lambda$ -plane cut along  $\Gamma$  is given by

$$T_{\Gamma}(\lambda) = -\frac{F(\lambda)}{\alpha_{\Gamma}(\lambda)}, \tag{5.7}$$

which appears to be identical to (5.3), except for the present case  $\alpha_{\Gamma}(\lambda)$  which is defined by (5.6). Since  $F(\lambda)$  is a meromorphic function, here we have defined the Riemann sheet structure of  $T_{\Gamma}(\lambda)$ . If again  $\lambda = \lambda_0$  is a solution to the equation  $\alpha_{\Gamma}(\lambda) = 0$ , it corresponds to a discrete eigenstate. And there is a pole in the scattering amplitude at  $\lambda = \lambda_0$ . By assumption  $F(\lambda)$  has a pole at  $\lambda = z_1$ . As  $\lambda$  approaches  $z_1$ , the dominant part of the denominator function  $\alpha_{\Gamma}(\lambda)$  is given by  $2iF(\lambda)$ , so

$$T(\lambda) \rightarrow i/2. \tag{5.8}$$

We see that  $T(\lambda)$  is regular on its second sheet at  $\lambda = z_1$ . On the other hand, on the physical sheet, the continuation of (5.7) is given by

$$T_I(\lambda) = -\frac{F(\lambda)}{\alpha_I(\lambda)}. \tag{5.9}$$

As  $\lambda \rightarrow z_1$ ,

$$T_I(\lambda) \propto \frac{1}{\lambda - z_1}. \tag{5.10}$$

It can be shown that this pole does not correspond to a discrete state in the generalized completeness relation.<sup>8</sup>

Next we look at the second case, which is specified by (5.5). To ensure the presence of the pole in  $\alpha_I(\lambda)$ , it is necessary to rewrite  $\alpha_I(\lambda)$  as follows:

$$\alpha_I(\lambda) = \lambda - m + \frac{1}{\pi} \int_{\Gamma} \frac{F(z')}{z' - \lambda} dz' + \frac{1}{\pi} \oint_{C_1} \frac{F(z')}{z' - \lambda} dz', \tag{5.11}$$

where  $C_1$  is a clockwise contour encircling  $z = z_1$ . The  $C_1$  contour integral gives the pole at  $z = z_1$ . For the present case,  $\alpha_{\Gamma}(z)$  is regular in the  $z$ -plane cut along  $\Gamma$ . The corresponding dispersion relation is given by

$$\alpha_{\Gamma}(\lambda) = \lambda - m + \frac{1}{\pi} \int_{\Gamma} \frac{F(z')}{z' - \lambda} dz'. \tag{5.12}$$

One can readily check the Cauchy equivalence of the (5.11) and (5.12) in the overlap region where both expressions are defined. We will leave the explicit verification to the reader.

The corresponding continued amplitude  $T_{\Gamma}(\lambda)$  is defined in the same manner as in (5.7). We see that there is an additional pole in  $T$  on its second sheet due to the presence of the pole in  $F(\lambda)$  and the fact that  $\alpha_{\Gamma}(\lambda)$  is regular in the plane cut along  $\Gamma$ .

Both of these cases illustrate the previously mentioned fact that not every pole of the scattering amplitude corresponds to a discrete state. For the case of scattering by a local potential these "redundant poles" without corresponding bound states have been known for quite sometime.<sup>11,12</sup> These poles are associated with the geometry of the potential rather than the dynamics, in that their location is unaffected by the overall strength of the interaction. As we have illustrated, the same results are obtained for the complex poles of the scattering amplitude coming from the poles of the form factor: They too are redundant poles and depend on the form and not on the strength of

the couplings. From the point of view of the analyticity and dispersion relations obeyed by partial-wave amplitudes in the analytic S matrix, form-factor singularities are conventionally associated with the "left-hand singularities". We recall that the positions of these singularities are indeed of kinematic origin: While they depend on the masses of exchanged particles, they are independent of the strength of interactions.

It is interesting to note that not only are there no discrete solutions corresponding to the redundant poles (and hence no terms in the completeness relation),<sup>26</sup> but these redundant poles do not contribute to the survival amplitude calculated using the complex contours as can be seen explicitly from (4.17). It follows that not all complex poles of the scattering amplitude correspond to decaying states which contribute complex exponential dependence to the survival amplitude. The complex poles which do contribute to the survival amplitude are the dynamical poles of the scattering amplitude which correspond to the discrete solutions of the modified eigenvalue problem. While we have carried out our demonstration here only for a particular class of models, it is valid more generally.

Finally, one word about phase equivalent systems. It is well known that two distinct interactions can yield the same scattering amplitude. And among such phase equivalent systems the number and the nature of the discrete states may change. Elsewhere we have shown<sup>12</sup> how to construct systems in which all poles of the scattering amplitude become dynamical poles. As the models change, so would the survival amplitudes. The survival amplitude makes use of *more detailed knowledge of the states of the interacting system* than is contained in the scattering amplitude.

ACKNOWLEDGMENT

This work was supported in part by ERDA, under Contract No. E(40-1)3992, and by Istituto Nazionale di Fisica Nucleare, Sezione di Milano.

APPENDIX A: ORTHONORMALITY AND COMPLETENESS RELATIONS

In this appendix we verify the orthonormality and the completeness relations for the generalized eigenfunctions defined in Sec. IV along some general contour  $\Gamma$ . When  $\Gamma$  is the positive real axis, they reduce to the corresponding relations for the Lee model discussed in Sec. II. To simplify the notation we shall write  $\alpha(z)$  in place of  $\alpha_\Gamma(z)$  for the function defined by (4.9).

The right and left eigenfunctions are respectively given by

$$\Psi_0 = \begin{pmatrix} \xi_0 \\ \phi_0(z) \end{pmatrix}, \quad \Psi_\lambda = \begin{pmatrix} \xi_\lambda \\ \phi_\lambda(z) \end{pmatrix}, \tag{A1}$$

and

$$\bar{\Psi}_0(z) = (\eta_0, \chi_0(z)), \quad \bar{\Psi}_\lambda(z) = (\eta_\lambda, \chi_\lambda(z)),$$

where

$$\xi_0 = \frac{1}{(\alpha'_0)^{1/2}}, \quad \phi_0(z) = \frac{g(z)}{\lambda_0 - z} \xi_0, \quad \xi_\lambda = \frac{\sqrt{\sigma_\lambda} g^*(\lambda^*)}{\alpha(\lambda + i\epsilon)}, \tag{A2a}$$

$$\phi_\lambda(z) = \frac{\delta(\lambda - z)}{\sqrt{\sigma_z}} + \frac{\sqrt{\sigma_\lambda} g^*(\lambda^*) g(z)}{(\lambda - z + i\epsilon) \alpha(\lambda + i\epsilon)},$$

and

$$\eta_0 = \frac{1}{(\alpha'_0)^{1/2}}, \quad \chi_0(z) = \frac{g^*(z^*)}{\lambda_0 - z} \eta_0, \quad \eta_\lambda = \frac{\sqrt{\sigma_\lambda} g(\lambda)}{\alpha(\lambda - i\epsilon)}, \tag{A2b}$$

$$\chi_\lambda(z) = \frac{\delta(\lambda - z)}{\sqrt{\sigma_z}} + \frac{\sqrt{\sigma_\lambda} g(\lambda) g^*(z^*)}{(\lambda - z - i\epsilon) \alpha(\lambda - i\epsilon)},$$

with

$$\alpha'_0 = \left. \frac{d\alpha_\Gamma}{dz} \right|_{z=\lambda_0}, \quad \sigma_z = \sigma(z), \quad \text{and} \quad \sigma_\lambda = \sigma(\lambda).$$

The orthonormality conditions, componentwise, are

$$\eta_0 \xi_0 + \int_\Gamma \chi_0(z) \phi_0(z) \sigma(z) dz = 1, \tag{A3a}$$

$$\eta_0 \xi_\lambda + \int_\Gamma \chi_0(z) \phi_\lambda(z) \sigma(z) dz = 0, \tag{A3b}$$

$$\eta_\lambda \xi_0 + \int_\Gamma \chi_\lambda(z) \phi_0(z) \sigma(z) dz = 0, \tag{A3c}$$

$$\eta_\lambda \xi_{\lambda'} + \int_\Gamma \chi_\lambda(z) \phi_{\lambda'}(z) \sigma(z) dz = \delta(\lambda - \lambda'). \tag{A3d}$$

The completeness relations to be checked are

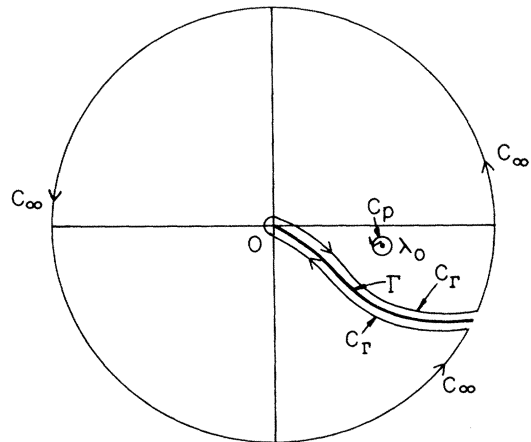

FIG. 6. The relation between the contours  $C_\infty$ ,  $C_\Gamma$ , and  $C_p$ .

$$\xi_0 \eta_0 + \int_{\Gamma} \xi_{\lambda} \eta_{\lambda} d\lambda = 1, \quad (\text{A4a}) \quad \frac{1}{\alpha'_0} + \frac{1}{\alpha'_0} \int_{\Gamma} \frac{\sigma_z g(z) g^*(z^*)}{(\lambda_0 - z)^2} dz$$

$$\xi_0 \chi_0(z') + \int_{\Gamma} \xi_{\lambda} \chi_{\lambda}(z') d\lambda = 0, \quad (\text{A4b}) \quad = \frac{1}{\alpha'_0} \left[ 1 + \frac{1}{2\pi i} \int_{C_{\Gamma}} \frac{\alpha(z) dz}{(\lambda_0 - z)^2} \right], \quad (\text{A5})$$

where the relation

$$\phi_0(z) \eta_0 + \int_{\Gamma} \phi_{\lambda}(z) \eta_{\lambda} d\lambda = 0, \quad (\text{A4c}) \quad \sigma_z g(z) g^*(z^*) = \frac{1}{2\pi i} [\alpha(z + i\epsilon) - \alpha(z - i\epsilon)], \quad (\text{A6})$$

has been used. The contours are shown in Fig. 6.

$$\phi_0(z) \chi_0(z') + \int_{\Gamma} \phi_{\lambda}(z) \chi_{\lambda}(z') d\lambda = \frac{\delta(z - z')}{\sigma(z)}. \quad (\text{A4d}) \quad \text{Notice the relation}$$

$$C_{\Gamma} + C_{\infty} = C_{\rho}. \quad (\text{A7})$$

1. Verify (A3a). The left-hand side is

So

$$\frac{1}{2\pi i} \int_{C_{\Gamma}} \frac{\alpha(z) dz}{(\lambda_0 - z)^2} = \frac{1}{2\pi i} \left[ \int_{C_{\rho}} \frac{\alpha(z) dz}{(\lambda_0 - z)^2} - \int_{C_{\infty}} \frac{\alpha(z) dz}{(\lambda_0 - z)^2} \right] = \alpha'_0 - 1. \quad (\text{A8})$$

Equations (A5) and (A8) lead to left-hand side (LHS) = 1.

2. Verify (A3b). The left-hand side is

$$\begin{aligned} \frac{1}{(\alpha'_0)^{1/2}} \frac{\sqrt{\sigma_{\lambda}} g^*(\lambda^*)}{\alpha(\lambda + i\epsilon)} + \int_{\Gamma} \frac{g^*(z^*)}{(\alpha'_0)^{1/2} (\lambda_0 - z)} \left[ \frac{\delta(\lambda - z)}{\sqrt{\sigma_z}} + \frac{\sqrt{\sigma_{\lambda}} g^*(\lambda^*) g(z)}{(\lambda - z + i\epsilon) \alpha(\lambda + i\epsilon)} \right] \sigma(z) dz \\ = \frac{1}{(\alpha'_0)^{1/2}} \frac{\sqrt{\sigma_{\lambda}} g^*(\lambda^*)}{\alpha(\lambda + i\epsilon)} + \frac{\sqrt{\sigma_{\lambda}} g^*(\lambda^*)}{(\alpha'_0)^{1/2} (\lambda_0 - \lambda)} + A, \end{aligned} \quad (\text{A9})$$

with

$$A = \frac{\sqrt{\sigma_{\lambda}} g^*(\lambda^*)}{(\alpha'_0)^{1/2} \alpha(\lambda + i\epsilon)} \int_{\Gamma} \frac{\sigma_z g^*(z^*) g(z)}{(\lambda_0 - z)(\lambda - z + i\epsilon)} dz = \frac{\sqrt{\sigma_{\lambda}} g^*(\lambda^*)}{(\alpha'_0)^{1/2} \alpha(\lambda + i\epsilon)} \frac{1}{2\pi i} \int_{C_{\Gamma}} \frac{\alpha(z) dz}{(\lambda_0 - z)(\lambda - z + i\epsilon)}. \quad (\text{A10})$$

Denote by  $C_{\lambda}$  the counterclockwise contour encircling the point  $z = \lambda + i\epsilon$ . Notice the relation

$$C_{\Gamma} = C_{\lambda} - C_{\infty}. \quad (\text{A11})$$

So

$$A = \frac{\sqrt{\sigma_{\lambda}}}{(\alpha'_0)^{1/2}} \frac{g^*(\lambda^*)}{\alpha(\lambda + i\epsilon)} \left[ \frac{-\alpha(\lambda + i\epsilon)}{\lambda_0 - \lambda} - 1 \right]. \quad (\text{A12})$$

Equations (A9) and (A12) lead to LHS = 0.

3. Verify (A3c). The left-hand side is

$$\begin{aligned} \frac{\sqrt{\sigma_{\lambda}} g(\lambda)}{\alpha(\lambda - i\epsilon)} \frac{1}{(\alpha'_0)^{1/2}} + \left[ \int_{\Gamma} \frac{\delta(\lambda - z)}{\sqrt{\sigma_z}} + \frac{\sqrt{\sigma_{\lambda}} g(\lambda) g^*(z^*)}{(\lambda - z - i\epsilon) \alpha(\lambda - i\epsilon)} \right] \frac{\sigma_z g(z)}{(\alpha'_0)^{1/2} (\lambda_0 - z)} dz \\ = \frac{\sqrt{\sigma_{\lambda}}}{(\alpha'_0)^{1/2}} \frac{g(\lambda)}{\alpha(\lambda - i\epsilon)} + \frac{\sqrt{\sigma_{\lambda}} g(\lambda)}{(\alpha'_0)^{1/2} (\lambda_0 - \lambda)} + A, \end{aligned} \quad (\text{A13})$$

with

$$A = \frac{\sqrt{\sigma_{\lambda}} g(\lambda)}{(\alpha'_0)^{1/2} \alpha(\lambda - i\epsilon)} \int_{\Gamma} \frac{\sigma_z g(z) g^*(z^*)}{(\lambda - z - i\epsilon)(\lambda_0 - z)} dz = \frac{\sqrt{\sigma_{\lambda}} g(\lambda)}{(\alpha'_0)^{1/2} \alpha(\lambda - i\epsilon)} \frac{1}{2\pi i} \int_{C_{\Gamma}} \frac{\alpha(z) dz}{(\lambda - z - i\epsilon)(\lambda_0 - z)}. \quad (\text{A14})$$

Denote by  $C_{\lambda}$  the counterclockwise contour encircling the pole of the integrand at  $z = \lambda - i\epsilon$ . For the present case,

$$C_{\Gamma} = C_{\lambda} - C_{\infty}. \quad (\text{A15})$$

This gives

$$A = \frac{\sqrt{\sigma_{\lambda}} g(\lambda)}{(\alpha'_0)^{1/2} \alpha(\lambda - i\epsilon)} \left[ -\frac{\alpha(\lambda - i\epsilon)}{\lambda_0 - \lambda} - 1 \right]. \quad (\text{A16})$$

Equations (A13) and (A16) lead to LHS=0.

4. Verify (A3d). The left-hand side is

$$\begin{aligned} & \frac{\sqrt{\sigma_\lambda}g(\lambda)}{\alpha(\lambda-i\epsilon)} \frac{\sqrt{\sigma_{\lambda'}}g^*(\lambda'^*)}{\alpha(\lambda'+i\epsilon)} + \int_{\Gamma} \left[ \frac{\delta(\lambda-z)}{\sqrt{\sigma_z}} + \frac{\sqrt{\sigma_\lambda}g(\lambda)g^*(z^*)}{(\lambda-z-i\epsilon)\alpha(\lambda-i\epsilon)} \right] \left[ \frac{\delta(\lambda'-z)}{\sqrt{\sigma_z}} + \frac{\sqrt{\sigma_{\lambda'}}g^*(\lambda'^*)g(z)}{(\lambda'-z+i\epsilon)\alpha(\lambda'+i\epsilon)} \right] \sigma(z)dz \\ & = \frac{(\sigma_\lambda\sigma_{\lambda'})^{1/2}g(\lambda)g^*(\lambda'^*)}{\alpha(\lambda-i\epsilon)\alpha(\lambda'+i\epsilon)} + \delta(\lambda-\lambda') + \frac{(\sigma_\lambda\sigma_{\lambda'})^{1/2}g(\lambda)g^*(\lambda'^*)}{(\lambda-\lambda'-i\epsilon)\alpha(\lambda-i\epsilon)} + \frac{(\sigma_\lambda\sigma_{\lambda'})^{1/2}g^*(\lambda'^*)g(\lambda)}{(\lambda'-\lambda+i\epsilon)\alpha(\lambda'+i\epsilon)} + A, \end{aligned} \quad (\text{A17})$$

$$A = \frac{(\sigma_\lambda\sigma_{\lambda'})^{1/2}g(\lambda)g^*(\lambda'^*)}{\alpha(\lambda-i\epsilon)\alpha(\lambda'+i\epsilon)} \int_{\Gamma} \frac{g(z)g^*(z^*)\sigma_z dz}{(\lambda-z-i\epsilon)(\lambda'-z+i\epsilon)} = \frac{(\sigma_\lambda\sigma_{\lambda'})^{1/2}g(\lambda)g^*(\lambda'^*)}{\alpha(\lambda-i\epsilon)\alpha(\lambda'+i\epsilon)} \frac{1}{2\pi i} \int_{C_{\Gamma}} \frac{\alpha(z)dz}{(\lambda-z-i\epsilon)(\lambda'-z+i\epsilon)}. \quad (\text{A18})$$

Denote the counterclockwise contours encircling the poles at  $z = \lambda - i\epsilon$  and  $z = \lambda' + i\epsilon$  by  $C_\lambda$  and  $C_{\lambda'}$  respectively. For the present case,

$$C_{\Gamma} = C_{\lambda} + C_{\lambda'} - C_{\infty}. \quad (\text{A19})$$

This relation leads to

$$\begin{aligned} A & = \frac{(\sigma_\lambda\sigma_{\lambda'})^{1/2}g(\lambda)g^*(\lambda'^*)}{\alpha(\lambda-i\epsilon)\alpha(\lambda'+i\epsilon)} \\ & \times \left[ -\frac{\alpha(\lambda-i\epsilon)}{\lambda'-\lambda+i\epsilon} - \frac{\alpha(\lambda'+i\epsilon)}{\lambda-\lambda'-i\epsilon} - 1 \right]. \end{aligned} \quad (\text{A20})$$

Equations (A20) and (A17) give LHS =  $\delta(\lambda - \lambda')$ .

5. Verify (A4a). The left-hand side is

$$\begin{aligned} & \frac{1}{\alpha'_0} + \int_{\Gamma} \frac{\sqrt{\sigma_\lambda}g^*(\lambda^*)}{\alpha(\lambda+i\epsilon)} \frac{\sqrt{\sigma_\lambda}g(\lambda)}{\alpha(\lambda-i\epsilon)} d\lambda \\ & = \frac{1}{\alpha'_0} + \frac{i}{2\pi} \int_{C_{\Gamma}} \frac{1}{\alpha(\lambda)} d\lambda = \frac{1}{\alpha'_0} + A. \end{aligned} \quad (\text{A21})$$

Notice the relation

$$C_{\Gamma} = C_{\rho} - C_{\infty}. \quad (\text{A22})$$

Therefore,

$$A = \frac{i}{2\pi} \left( \frac{2\pi i}{\alpha'_0} - 2\pi i \right) = -\frac{1}{\alpha'_0} + 1. \quad (\text{A23})$$

Equations (A21) and (A23) lead to LHS=1.

6. Verify (A4b). The left-hand side is

$$\begin{aligned} & \frac{g^*(z^*)}{\alpha'_0(\lambda_0-z')} + \int_{\Gamma} \frac{\sqrt{\sigma_\lambda}g^*(\lambda^*)}{\alpha(\lambda+i\epsilon)} \\ & \times \left[ \frac{\delta(\lambda-z')}{\sqrt{\sigma_z}} + \frac{\sqrt{\sigma_\lambda}g(\lambda)g^*(z'^*)}{(\lambda-z'-i\epsilon)\alpha(\lambda-i\epsilon)} \right] d\lambda \\ & = \frac{g^*(z')}{\alpha'(\lambda_0-z')} + \frac{g^*(z'^*)}{\alpha(z'+i\epsilon)} + A, \end{aligned} \quad (\text{A24})$$

where

$$A = \frac{g^*(z'^*)}{-2\pi i} \int_{C_{\Gamma}} \frac{d\lambda}{(\lambda-z'-i\epsilon)\alpha(\lambda)}. \quad (\text{A25})$$

Denote by  $C_{z'}$  the counterclockwise contour encircling the pole at  $\lambda = z' + i\epsilon$ . There is the relation

$$C_{\Gamma} = C_{\rho} + C_{z'} - C_{\infty} = C_{\rho} + C_{z'}. \quad (\text{A26})$$

This leads to

$$A = -g^*(z'^*) \left[ \frac{1}{\alpha'_0(\lambda_0-z')} + \frac{1}{\alpha(z'+i\epsilon)} \right]. \quad (\text{A27})$$

In turn from (A24) and (A27), LHS=0.

7. Verify (A4c). The left-hand side is

$$\frac{g(z)}{(\alpha'_0)^{1/2}(\lambda_0-z)} \frac{1}{(\alpha'_0)^{1/2}} + \int_{\Gamma} \left[ \frac{\delta(\lambda-z)}{\sqrt{\sigma_z}} + \frac{\sqrt{\sigma_\lambda}g^*(\lambda^*)g(z)}{(\lambda-z+i\epsilon)\alpha(\lambda-i\epsilon)} \right] \frac{\sqrt{\sigma_\lambda}g(\lambda)}{\alpha(\lambda-i\epsilon)} d\lambda = \frac{g(z)}{\alpha'_0(\lambda_0-z)} + \frac{g(z)}{\alpha(z-i\epsilon)} + A, \quad (\text{A28})$$

where

$$A = g(z) \int_{\Gamma} \frac{g^*(\lambda^*)g(\lambda)\sigma_\lambda d\lambda}{(\lambda-z+i\epsilon)\alpha(\lambda+i\epsilon)\alpha(\lambda-i\epsilon)} = \frac{ig(z)}{2\pi} \int_{C_{\Gamma}} \frac{d\lambda}{(\lambda-z+i\epsilon)\alpha(\lambda)}. \quad (\text{A29})$$

Denote by  $C_z$  the counterclockwise contour encircling the pole at  $\lambda = z - i\epsilon$ . Using the relation

$$C_{\Gamma} = C_z + C_{\rho} - C_{\infty} = C_z + C_{\rho}, \quad (\text{A30})$$

we get

$$A = -g(z) \left[ \frac{1}{\alpha(z-i\epsilon)} + \frac{1}{\alpha'_0(\lambda_0-z)} \right]. \quad (\text{A31})$$

Combining (A29) and (A30) gives LHS=0.

8. Verify (A4d). The left-hand side is

$$\begin{aligned} & \frac{g(z)}{(\alpha'_0)^{1/2}(\lambda_0 - z)} \frac{g^*(z'^*)}{(\alpha'_0)^{1/2}(\lambda_0 - z')} + \int_{\Gamma} \left[ \frac{\delta(\lambda - z)}{\sqrt{\sigma_z}} + \frac{\sqrt{\sigma_\lambda} g^*(\lambda^*) g(z)}{(\lambda - z + i\epsilon)\alpha(\lambda + i\epsilon)} \right] \left[ \frac{\delta(\lambda - z')}{\sqrt{\sigma_{z'}}} + \frac{\sqrt{\sigma_\lambda} g(\lambda) g^*(z'^*)}{(\lambda - z' - i\epsilon)\alpha(\lambda - i\epsilon)} \right] d\lambda \\ & = \frac{g(z)g^*(z'^*)}{\alpha'_0(\lambda_0 - z)(\lambda_0 - z')} + \frac{\delta(z - z')}{\sigma_z} + \frac{g^*(z'^*)g(z)}{(z' - z + i\epsilon)\alpha(z' + i\epsilon)} + \frac{g(z)g^*(z'^*)}{(z - z' - i\epsilon)\alpha(z - i\epsilon)} + A, \end{aligned} \quad (\text{A32})$$

with

$$A = \frac{ig(z)g^*(z'^*)}{2\pi} \int_{C_\Gamma} \frac{d\lambda}{(\lambda - z + i\epsilon)(\lambda - z' - i\epsilon)\alpha(\lambda)}. \quad (\text{A33})$$

Denote the counterclockwise contours encircling the poles at  $\lambda = z - i\epsilon$  and  $\lambda = z' + i\epsilon$  by  $C_z$  and  $C_{z'}$ , respectively. The relation

$$C_\Gamma = C_z + C_{z'} + C_p \quad (\text{A34})$$

leads to

$$A = -g(z)g^*(z'^*) \left[ \frac{1}{\alpha'(\lambda_0 - z)(\lambda_0 - z')} + \frac{1}{(z - z' - i\epsilon)\alpha(z - i\epsilon)} + \frac{1}{(z' - z + i\epsilon)\alpha(z' + i\epsilon)} \right]. \quad (\text{A35})$$

Equations (A32) and (A35) now yield  $\text{LHS} = \delta(z - z')/\sigma_z$

#### APPENDIX B: THE INTEGRAL $F(t)$

Here we evaluate the integral

$$F(t) = \int_0^\infty du \frac{e^{-tu} u^\epsilon}{(u - ib)^\rho}. \quad (\text{B1})$$

From Eq. (3.383.8) of Gradshteyn and Ryzhik,<sup>27</sup>

$$\int_0^\infty du \frac{e^{-\mu u} u^{\nu-1}}{(u + \beta)^\rho} = \beta^{(\nu-\rho-1)/2} \mu^{(\rho-\nu-1)/2} e^{\beta\mu/2} \Gamma(\nu) W_{(1-\nu-\rho)/2, (\nu-\rho)/2}(\beta\mu). \quad (\text{B2})$$

$\Gamma(z)$  is the gamma function and  $W_{\lambda, \mu}(z)$  is the Whittaker function. Using (B2) we get

$$F(t) = (-ib)^{(\epsilon-\rho)/2} t^{-\epsilon/2 + (\rho-2)/2} e^{-ibt/2} \Gamma(1 + \epsilon) W_{(\epsilon+\rho)/2, (\epsilon-\rho+1)/2}(-ibt). \quad (\text{B3})$$

But according to Eq. (13.1.3) of Abramowitz and Stegun,<sup>28</sup> we have

$$W_{\lambda, \mu}(z) = e^{-z/2} z^{1/2 + \mu} U\left(\frac{1}{2} + \mu - \lambda, 1 + 2\mu; z\right), \quad (\text{B4})$$

and Eq. (13.1.3) gives

$$U(a, b, z) = \frac{\pi}{\sin\pi b} \left[ \frac{M(a, b; z)}{\Gamma(1+a-b)\Gamma(b)} - z^{1-b} \frac{M(1+a-b, 2-b, z)}{\Gamma(a)\Gamma(2-b)} \right]. \quad (\text{B5})$$

The small- $z$  expansion of the  $M$  function is given by [Eq. (13.1.2) of Ref. 28]

$$M(a, b, z) = 1 + (a/b)z + O(z^2). \quad (\text{B6})$$

Combining (B3), (B4), (B5), and (B6), and making use of the identity  $\Gamma(z)\Gamma(1-z) = \pi/\sin z$  for small  $t$ , we arrive at the expression

$$F(t) = \left[ (-ib)^{1+\epsilon-\rho} \frac{\pi\Gamma(\epsilon+1)}{\sin\pi(\epsilon-\rho)} \frac{1}{\Gamma(\rho)\Gamma(\epsilon+2-\rho)} - t^{\rho-1-\epsilon} \Gamma(1-\rho+\epsilon) \right] [1 + O(t)]. \quad (\text{B7})$$

\*Permanent address: Istituto di Fisica dell'Università,  
Via Celoria 16, 20133 Milano, Italy.

<sup>1</sup>C. B. Chiu, E. C. G. Sudarshan, and B. Misra, Phys.  
Rev. D **16**, 520 (1977).

<sup>2</sup>L. A. Khalifin, Zh. Eksp. Teor. Fiz. **33**, 1371 (1957) [Sov.  
Phys.—JETP **6**, 1053 (1958)]; Zh. Eksp. Teor. Fiz.  
Pis'ma Red. **8**, 106 (1968) [JETP Lett. **8**, 65 (1968)];  
see also earlier references cited therein.

<sup>3</sup>R. Paley and W. Wiener, *Fourier Transforms in the  
Complex Domain* (American Mathematical Society,  
Providence, Rhode Island, 1934), Theorem XII, p. 18.

<sup>4</sup>L. Fonda, in Proceedings of the XIII Winter School of  
Theoretical Physics, Karpacz, Poland, 1976 (unpub-  
lished), and references cited therein.

<sup>5</sup>B. Misra and E. C. G. Sudarshan, J. Math. Phys. **18**,  
756 (1977).

- <sup>6</sup>B. Misra and K. B. Sinha, *Helv. Phys. Acta* **50**, 99 (1977).
- <sup>7</sup>M. De Haan, C. George, F. Mayné, and I. Prigogine, Université Libre de Bruxelles report 1976 (unpublished).
- <sup>8</sup>E. C. G. Sudarshan, C. B. Chiu, Vittorio Gorini, and Guido Parravicini (unpublished).
- <sup>9</sup>T. D. Lee, *Phys. Rev.* **95**, 1329 (1954).
- <sup>10</sup>K. O. Friedrichs, *Commun. Pure Appl. Math.* **1**, 361 (1948). See Also P. A. M. Dirac, *Principles of Quantum Mechanics* (Clarendon Press, Oxford, England, 1935), 2nd ed., Chap. 9.
- <sup>11</sup>S. T. Ma, *Phys. Rev.* **69**, 668 (1946); **71**, 195 (1947); D. Ter Haar, *Physica* **12**, 501 (1946).
- <sup>12</sup>S. N. Biswas, T. Pradhan, and E. C. G. Sudarshan, *Nucl. Phys.* **B50**, 269 (1972).
- <sup>13</sup>J. Rau, *Phys. Rev.* **129**, 1880 (1963); J. Mehra and E. C. G. Sudarshan, *Nuovo Cimento* **B11**, 215 (1972); H. Ekstein and A. J. F. Siegert, *Ann. Phys. (N.Y.)* **63**, 509 (1971); also, L. Fonda and collaborators have also investigated extensively along this direction. In particular, assuming that the interaction between the experimental apparatus and the measured system is a Poisson process, Degasperis *et al.* have derived an integral expression relating the measured lifetime to the nondecay probability for the undisturbed system and the mean frequency of the interactions. [See A. Degasperis, L. Fonda, and G. C. Ghirardi, *Nuovo Cimento* **21A**, 471 (1974).] In the limit of infinitely frequent interactions this leads to nondecay. On the other hand, assuming the measuring interaction takes place at regular intervals, J. Rau (in the reference cited earlier) derived another law for the measured lifetime, which also leads to nondecay in the same limit. The theorem on Zeno's paradox given in Ref. 5 proves the nondecay result quite generally, which includes the above-mentioned results as special cases.
- <sup>14</sup>J. Aguilar and J. M. Combes, *Commun. Math. Phys.* **22**, 269 (1971).
- <sup>15</sup>E. Balslev and J. M. Combes, *Commun. Math. Phys.* **22**, 280 (1971).
- <sup>16</sup>J. M. Combes, in *Scattering Theory in Mathematical Physics*, edited by J. A. Lavita and J. P. Marchand (Reidel, Dordrecht, Holland, 1974).
- <sup>17</sup>B. Simon, *Ann. Math.* **97**, 247 (1973).
- <sup>18</sup>R. A. Weder, *J. Math. Phys.* **15**, 20 (1974).
- <sup>19</sup>H. Baumgärtel, *Math. Nachr.* **75**, 133 (1976). See also A. Grossman, *J. Math. Phys.* **5**, 1025 (1964).
- <sup>20</sup>V. Weisskopf and E. P. Wigner, *Z. Phys.* **63**, 54 (1930).
- <sup>21</sup>E. B. Davies, *J. Math. Phys.* **15**, 2036 (1974).
- <sup>22</sup>J. W. Middleton and W. C. Schieve, *Physica* **63**, 139 (1973). See also P. F. Palmer, *J. Math. Phys.* **18**, 527 (1977) and Ph.D. thesis, Oxford University, 1976 (unpublished).
- <sup>23</sup>E. B. Davies, *Commun. Math. Phys.* **39**, 91 (1974); *Math. Ann.* **219**, 147 (1976). See also the review paper: V. Gorini, A. Frigerio, M. Verri, A. Kossakowski, and E. C. G. Sudarshan, *Rep. Math. Phys.* (to be published), and E. B. Davies, *Rend. Sem. Mat. Fis. Milano* (to be published).
- <sup>24</sup>Technically speaking,  $\rho(\lambda)$  can accidentally be infinite at some discrete positive value of  $\lambda$ . We do not consider this possibility in this paper.
- <sup>25</sup>To avoid an unnecessary burdening of the formalism here as well as in the treatment of the Lee model in Sec. IV we shall confine ourselves to discussing the case when the zeros of  $\gamma(z)$  in the second sheet are simple. An  $n$ th-order zero at some  $\lambda = \lambda_0$  would give rise in the summation of the right-hand side of (3.14) [or (4.17)] to the product of the exponential  $e^{-i\lambda_0 t}$  times a polynomial in  $t$  of order  $n - 1$ . This case can also be dealt with as in Sec. IV in terms of generalized states, but it requires the additional introduction of so-called associated functions of the Hamiltonian. For a detailed discussion of this point, we refer to our paper in preparation (Ref. 8).
- <sup>26</sup>Actually, there are certain pathological cases when a redundant pole at some  $\lambda = \lambda_1$  gives rise to one or more discrete states in the completeness relation. This situation takes place whenever a pole of the form factor  $g(z)$  at  $\lambda = \lambda_1$  is matched by a zero (of lower order) of  $g^*(z^*)$  at the same point, or vice versa [note that this is obviously impossible if  $g(z)$  is real analytic]. However, it is still true even in this case that the geometrical singularity does not affect the survival amplitude. The discussion of these pathologies requires a more refined mathematical treatment which would not be appropriate here and will be given in Ref. 8.
- <sup>27</sup>I. S. Gradshteyn and I. M. Ryzhik, *Tables of Integrals, Series and Products*, 4th ed. (Academic, New York, 1965).
- <sup>28</sup>*Handbook of Mathematical Functions*, edited by M. Abramowitz and I. A. Stegun, National Bureau of Standards Applied Mathematics Series, No. 55 (U.S.G.P.O., Washington, D.C., 1964).



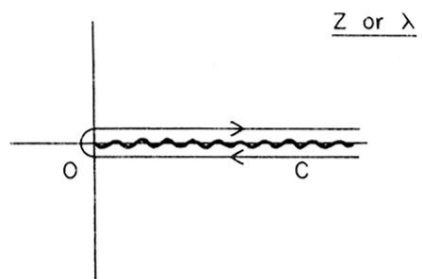

FIG. 1. The contour  $C$ .

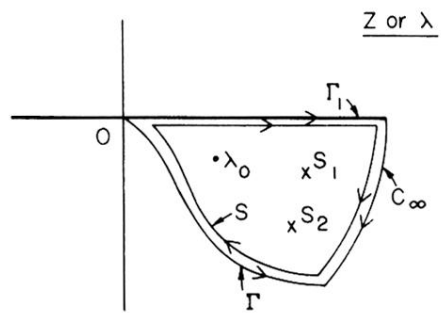

FIG. 2. The contours  $\Gamma_1$ ,  $\Gamma$ ,  $C_\infty$ , and  $S$ .  $S_1$  and  $S_2$  denote the locations of  $F(z)$  singularities.

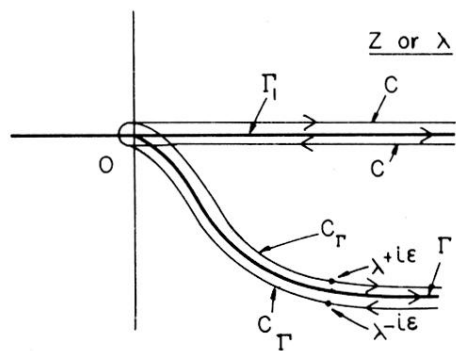

FIG. 3. The curves  $\Gamma_1$  and  $\Gamma$  and their corresponding contours  $C$  and  $C_\Gamma$ .

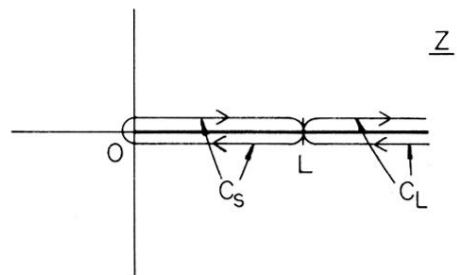

FIG. 4. The contours  $C_S$  and  $C_L$ .

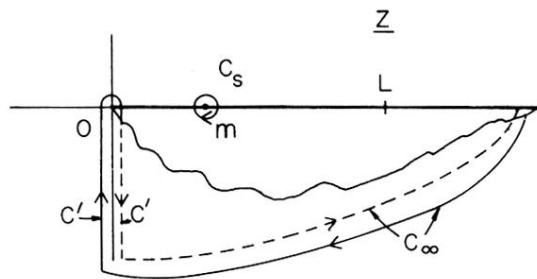

FIG. 5. Deformation of the contour  $C$  into contours  $C_s$ ,  $C'$ , and  $C_\infty$ .

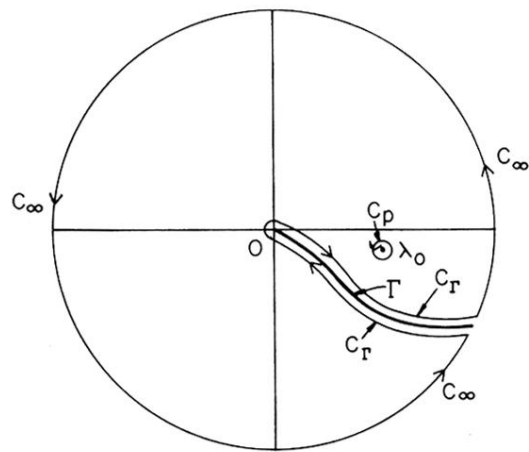

FIG. 6. The relation between the contours  $C_\infty$ ,  $C_\Gamma$ , and  $C_p$ .